

Suspended Mass including (Battery and Main Board)	4.7 KG
Enclosure Material	DX51D
Enclosure Thickness	1.5 mm

Commodit:		SURFACE PROTECTION:		DEBURR AND BREAK SHARP EDGES		DO NOT SCALE DRAWING		PROJECT: Inspector	
UNLESS OTHERWISE SPECIFIED: DIMENSIONS ARE IN MILLIMETERS		Coating:		Color/RAL#:		Finish:		DIMENSIONS INCLUDING COATING TOLERANCING : ISO 8015 - GENERAL TOLERANCE	
SURFACE FINISH:		Heat treatment:		Hardness:		FIRST ANGLE PROJECTION			
TOLERANCES: EN ISO 2768-mK									
						TITLE: Inspector main unit installation			
						Reference #: R2160501-230-012			
DESIGN: Moh. A. Moniem		DATE:		MATERIAL: SEE PARTS		REV. #: INS-001		REVISION: A.4	
DRAWN: Amr Saber		02-Mar-20						SIZE: A2	
APPVD:		02-Mar-20		WEIGHT: 4695.77 grams		SCALE: DON NOT SCALE		SHEET 1 OF 2	

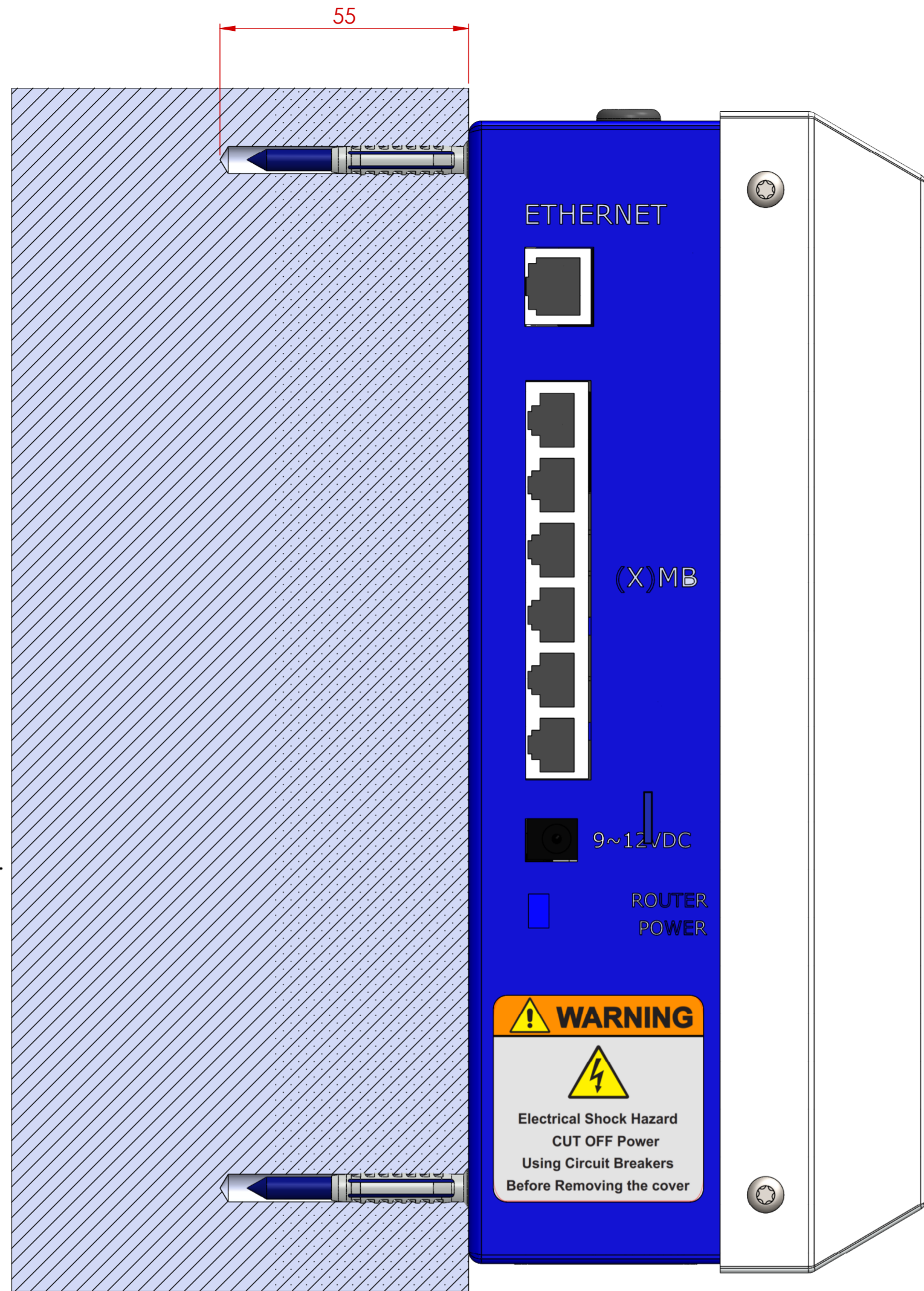

VIEW H

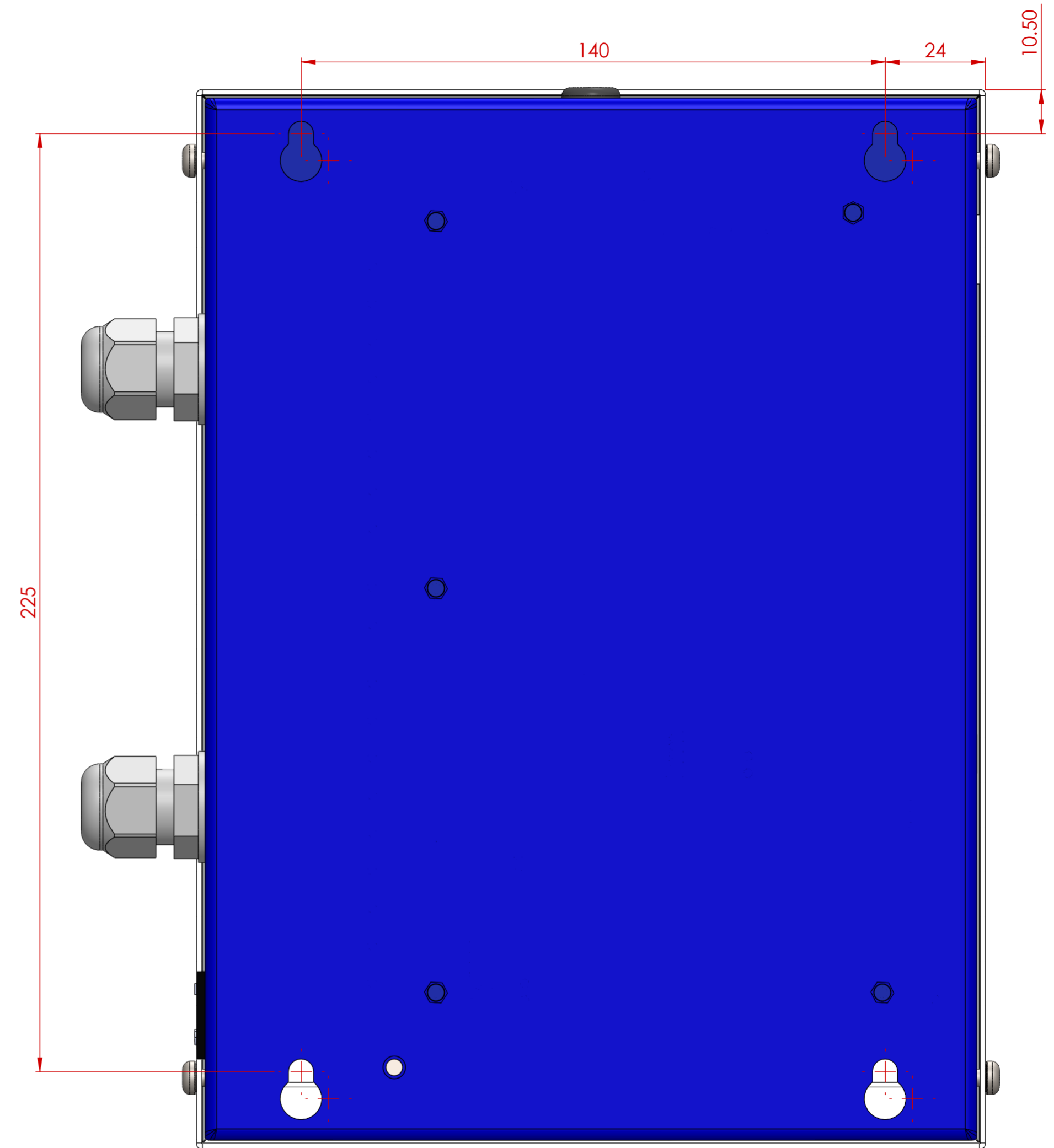

H ←

Anchor specification	
Plug	
Type	fischer SX
Drill Size	6
Material	Nylon
Recommended Tensile Load for Concrete C 25/30	0.65 kN
Screw	
DIN	7981 C
Type	Pozidriv cross recessed pan head tapping screws
Screwdriver	PZ2
Material	Steel Case - hardened 450 HV
Coating	Zinc Plated
Diameter	ST 4.8

Recommended Wall Material							
Concrete	Natural Stone	Limestone / Brick	Hollow limestone / Hollow Brick	Aircrete	Plaster walls	Gypsum fiberboard	
●	●	●	●	●	●	○	
●	Suitable		○	Not Suitable			

Commodit:	SURFACE PROTECTION:	DEBURR AND BREAK SHARP EDGES	DO NOT SCALE DRAWING	PROJECT: Inspector
UNLESS OTHERWISE SPECIFIED: DIMENSIONS ARE IN MILLIMETERS	Coating:		DIMENSIONS INCLUDING COATING TOLERANCING : ISO 8015 - GENERAL TOLERANCE	FIRST ANGLE PROJECTION
SURFACE FINISH:	Color/RAL#:	Finish:	TITLE: Inspector main unit installation Reference #: R2160501-230-012	
TOLERANCES: EN ISO 2768-mK	Heat treatment:	Hardness:		
			BB#: INS-001	
			REVISION: A.4	
DESIGN: Moh. A. Moniem	DATE:	MATERIAL: SEE PARTS	SCALE: DON NOT SCALE	SHEET 2 OF 2
DRAWN: Amr Saber	02-Mar-20	WEIGHT: 4695.77 grams		
APPVD:	02-Mar-20			

This drawing and any information or descriptive material set out on it are the confidential and copyright property of BioBusiness® and MUST NOT BE DISCLOSED, COPIED, LOANED in whole or part or used for any purpose without written permission of BioBusiness®.

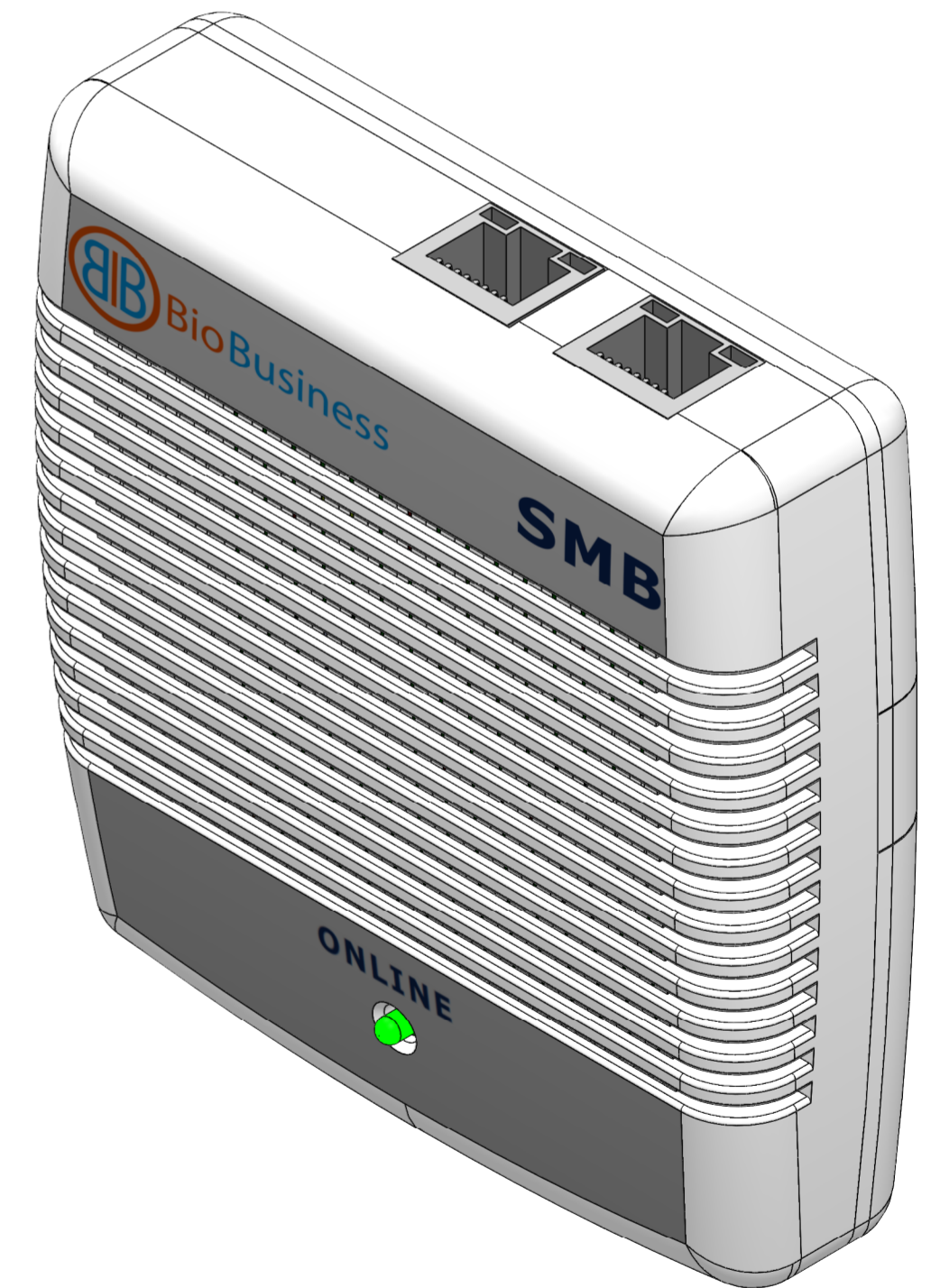
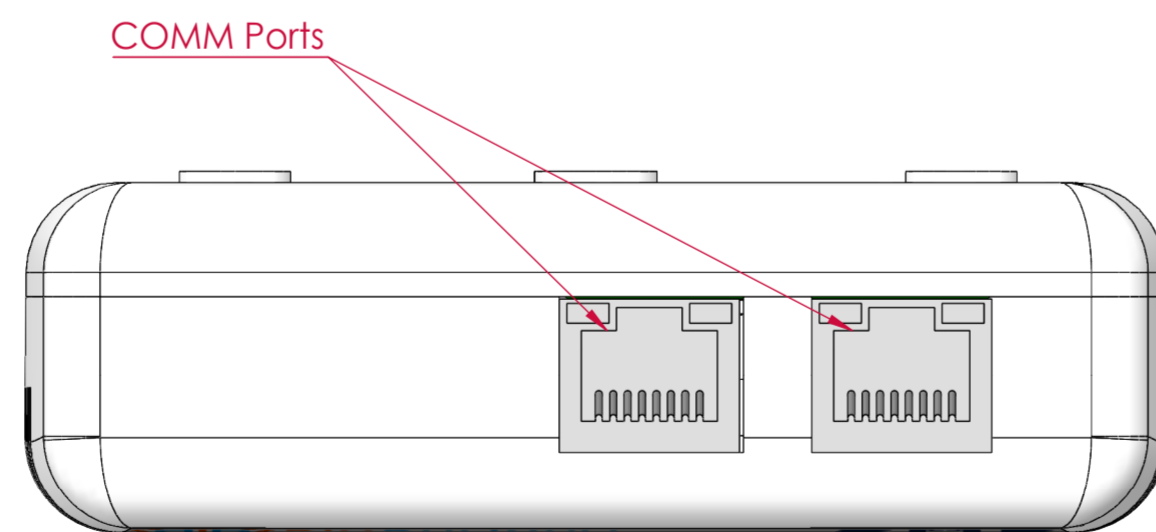
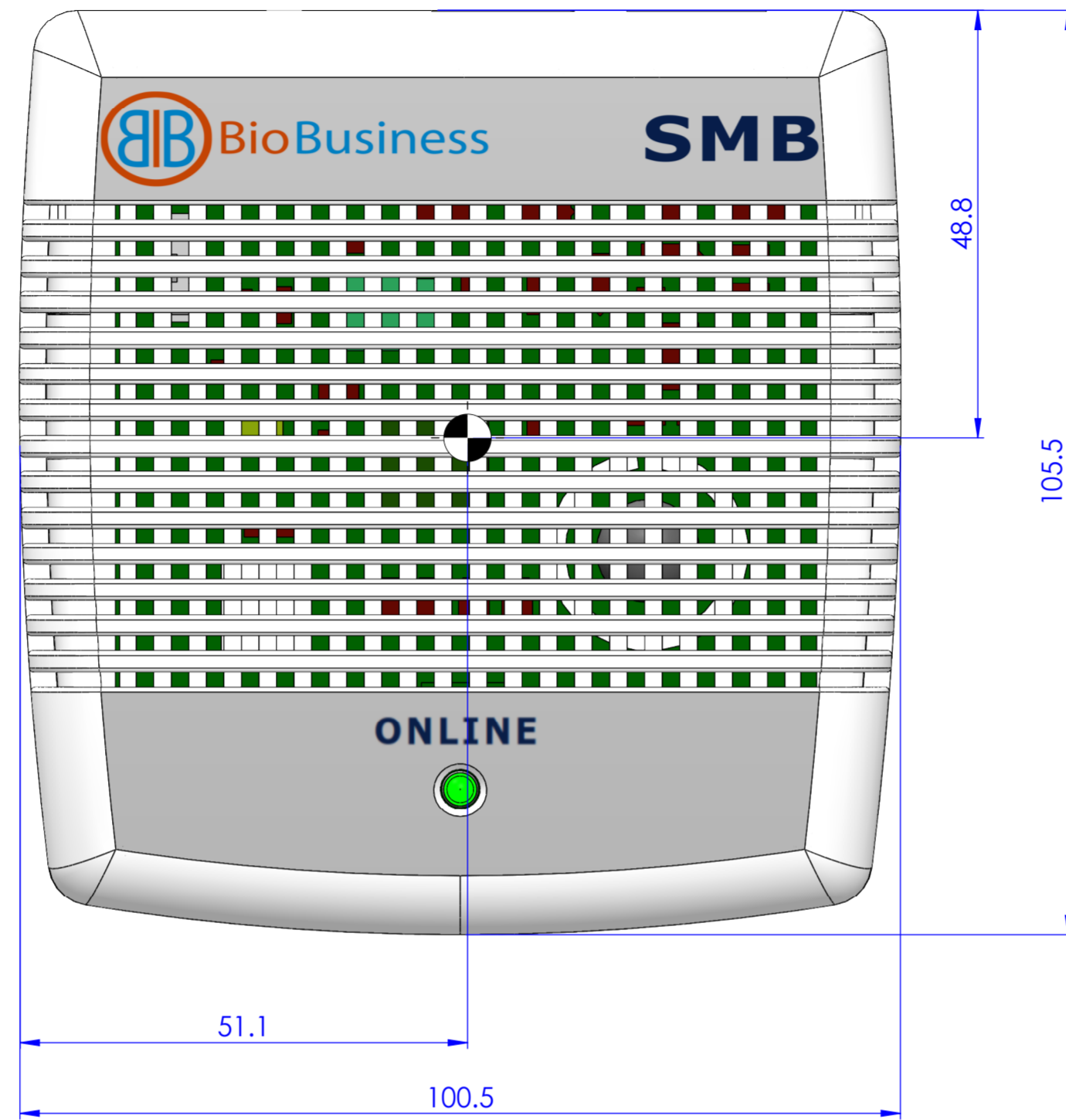
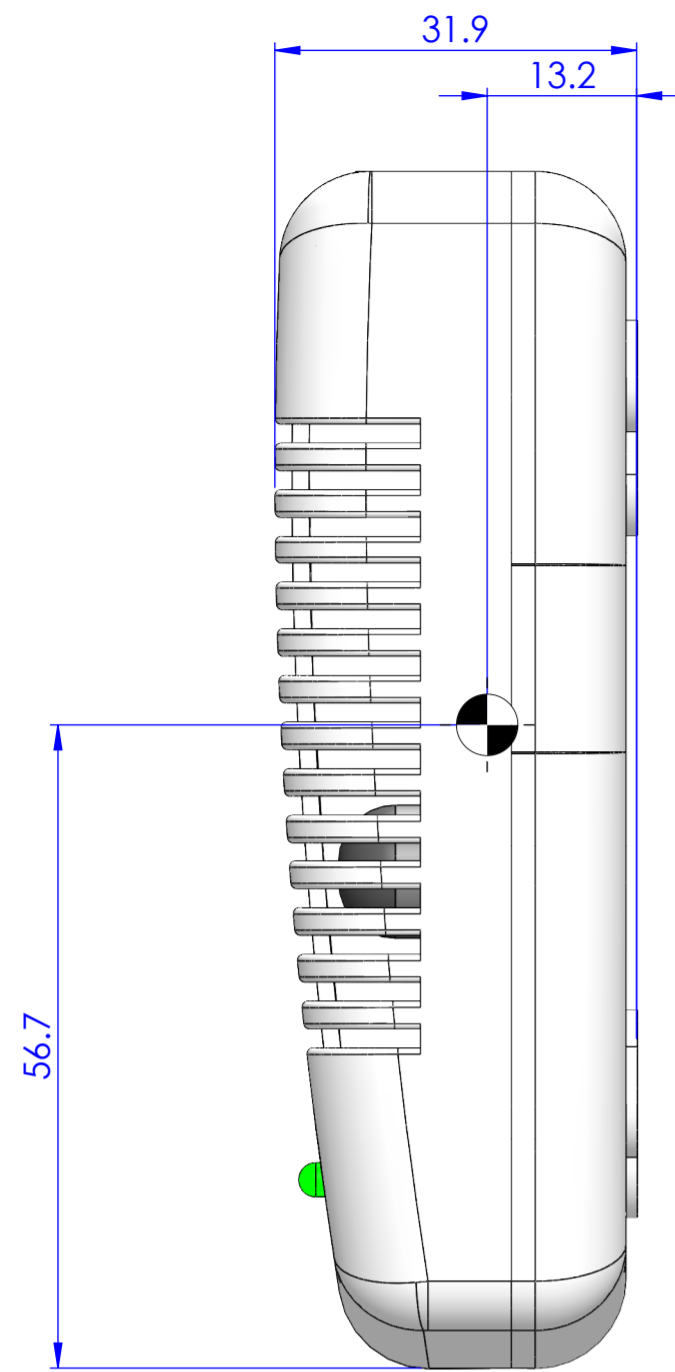

Weight without ATMP	116g
Enclosure Material	ABS
Enclosure Thickness	2 mm



Commodit:		SURFACE PROTECTION:		DEBURR AND BREAK SHARP EDGES		DO NOT SCALE DRAWING		PROJECT: Inspector	
UNLESS OTHERWISE SPECIFIED: DIMENSIONS ARE IN MILLIMETERS		Coating:		Color/RAL#:		Finish:		DIMENSIONS INCLUDING COATING TOLERANCING : ISO 8015 - GENERAL TOLERANCE	
SURFACE FINISH:		Heat treatment:		Hardness:		FIRST ANGLE PROJECTION			
TOLERANCES: EN ISO 2768-mK									
						TITLE: SMB Unit			
						Reference #: R2160501-230-013			
DESIGN		DATE		MATERIAL:		REV. #:		REVISION	
DRAWN		24-Oct-17		SEE PARTS		MODSB4A010		2	
APPVD		09-Mar-20		WEIGHT: 95.88 grams		SCALE: DON NOT SCALE		SHEET 1 OF 2	
		09-Mar-20						A2	

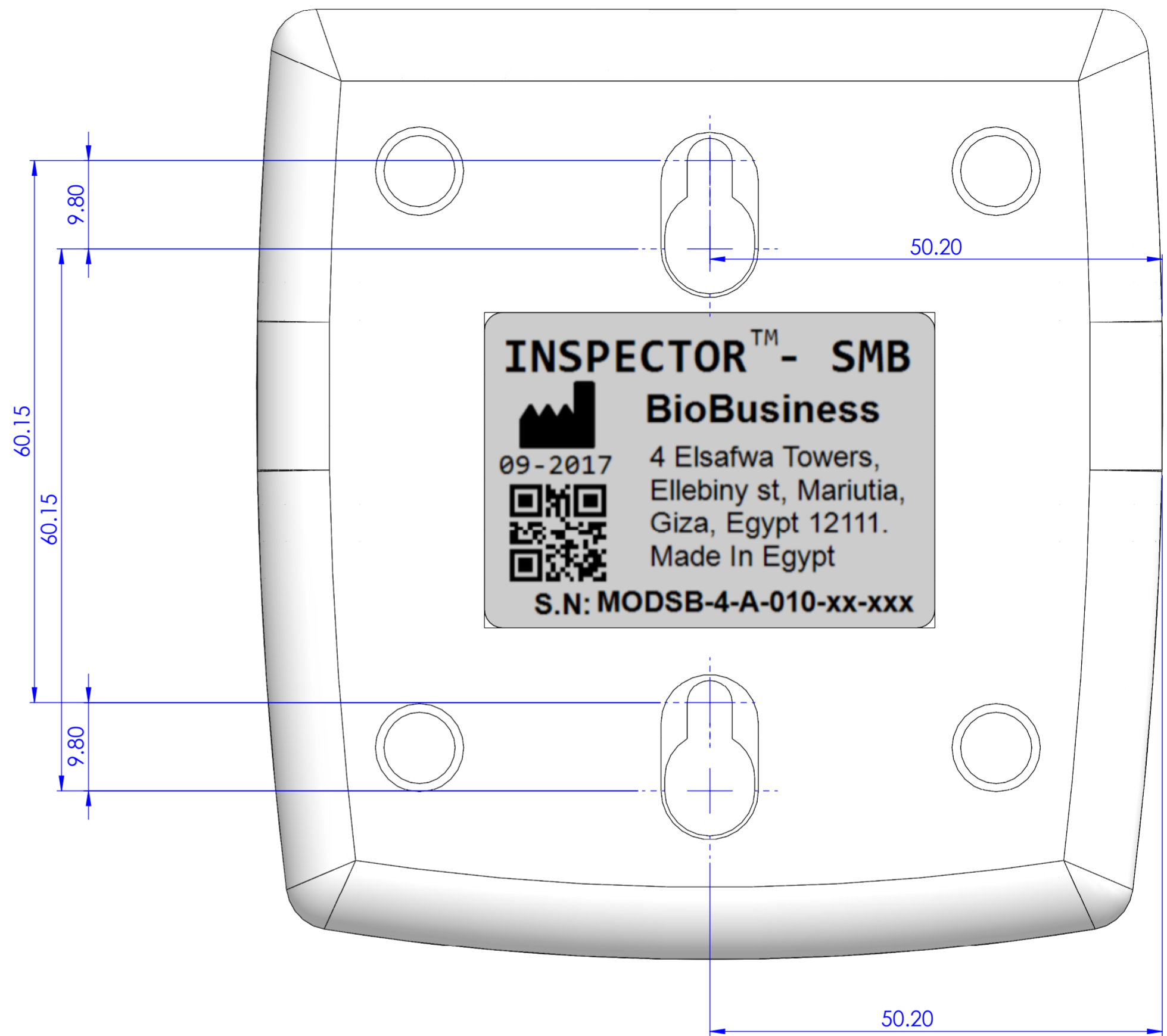
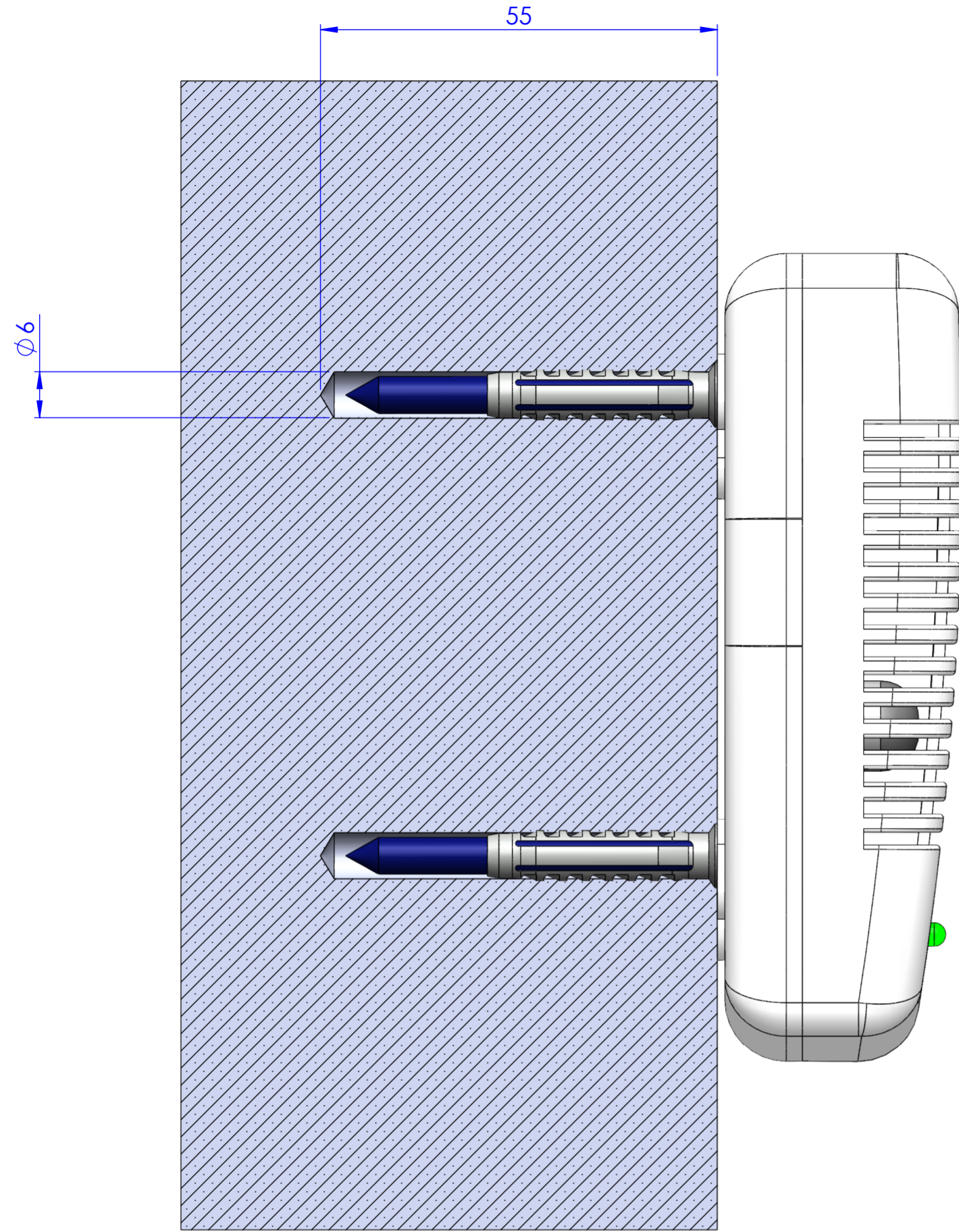

Anchor specification	
Plug	
Type	fischer SX
Drill Size	6
Material	Nylon
Recommended Tensile Load for Concrete C 25/30	0.4 kN
Screw	
DIN	7982 C
Type	Phillips flat countersunk head tapping screws
Screwdriver	PH2
Material	Steel Case - hardened 450 HV
Coating	Zinc Plated
Diameter	ST 4.7

Recommended Wall Material							
Concrete	Natural Stone	Limestone / Brick	Hollow limestone / Hollow Brick	Aircrete	Plaster walls	Gypsum fiberboard	
●	●	●	●	●	●	○	
●	Suitable		○	Not Suitable			

Commodit:		SURFACE PROTECTION:		DEBURR AND BREAK SHARP EDGES		DO NOT SCALE DRAWING		PROJECT: Inspector	
UNLESS OTHERWISE SPECIFIED: DIMENSIONS ARE IN MILLIMETERS		Coating:		Color/RAL#:		FINISH:		DIMENSIONS INCLUDING COATING TOLERANCING : ISO 8015 - GENRAL TOLERANCE	
SURFACE FINISH:		Heat treatment:		Hardness:		FIRST ANGLE PROJECTION			
TOLERANCES: EN ISO 2768-mK									
						TITLE: SMB Unit			
						Reference #: R2160501-230-013			
DESIGN		DATE		MATERIAL:		REV. #:		REVISION	
DRAWN		APPVD		SEE PARTS		MODSB4A010		2	
Amr Saber		09-Mar-20		09-Mar-20		WEIGHT: 95.88 grams		SCALE: DON NOT SCALE SHEET 2 OF 2 A2	

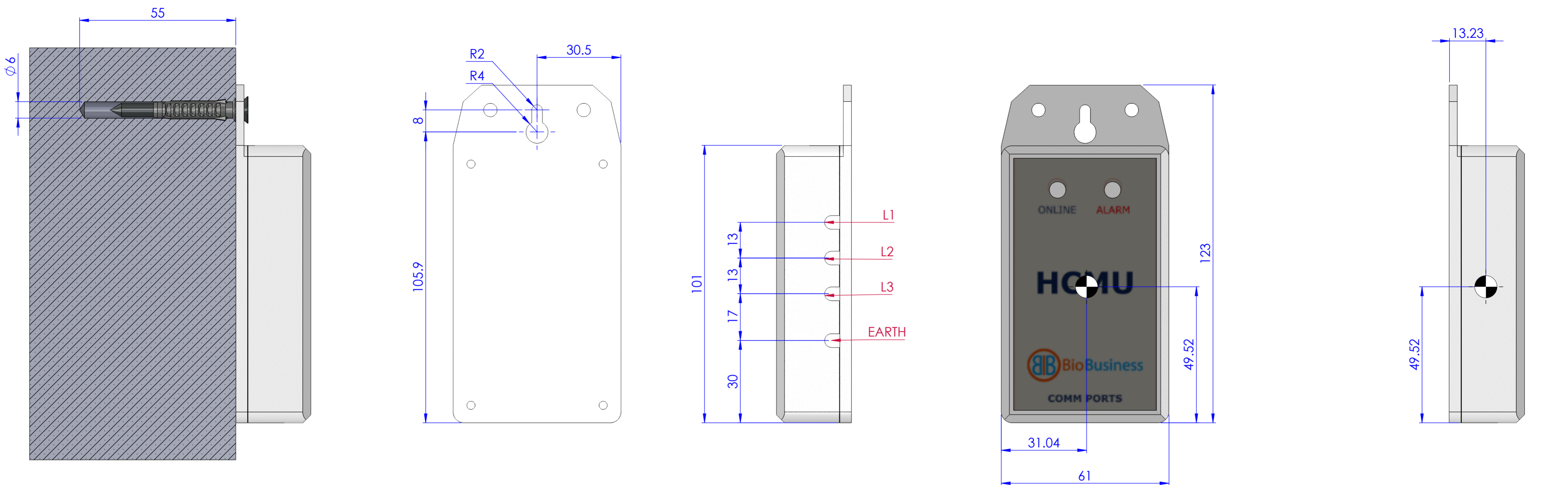

Anchor specification	
Plug	
Type	fischer SX
Drill Size	6
Material	Nylon
Recommended Tensile Load for Concrete C 25/30	0.4 kN
Screw	
DIN	7982 C
Type	Phillips flat countersunk head tapping screws
Screwdriver	PH2
Material	Steel Case - hardened 450 HV
Coating	Zinc Plated
Diameter	ST 4.8

Recommended Wall Material						
Concrete	Natural Stone	Limestone / Brick	Hollow limestone / Hollow Brick	Aircrete	Plaster walls	Gypsum fiberboard
•	•	•	•	•	•	○
• Suitable			○ Not Suitable			

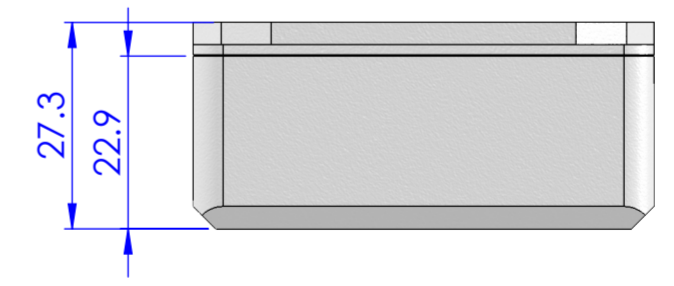

Weight without coils	89 g
Enclosure Material	ABS
Enclosure Thickness	2 mm



Commodit: Machined		SURFACE PROTECTION:		DEBURR AND BREAK SHARP EDGES		DO NOT SCALE DRAWING		PROJECT: Inspector	
UNLESS OTHERWISE SPECIFIED: DIMENSIONS ARE IN MILLIMETERS		Coating:		Color/RAL#:		FINISH:		DIMENSIONS INCLUDING COATING TOLERANCING : ISO 8015 - GENERAL TOLERANCE	
SURFACE FINISH:		Heat treatment:		Hardness:		FIRST ANGLE PROJECTION		TITLE: HCMU Unit	
TOLERANCES: EN ISO 2768-mK								Reference #: R2160501-230-014	
				NAME:		DATE:		MATERIAL: SEE PARTS	
				DRAWN: Amr Saber		09-Mar-20		APPYD: 09-Mar-20	
				REVISION: 2		SIZE: A2		SCALE: DON NOT SCALE SHEET 1 OF 1	

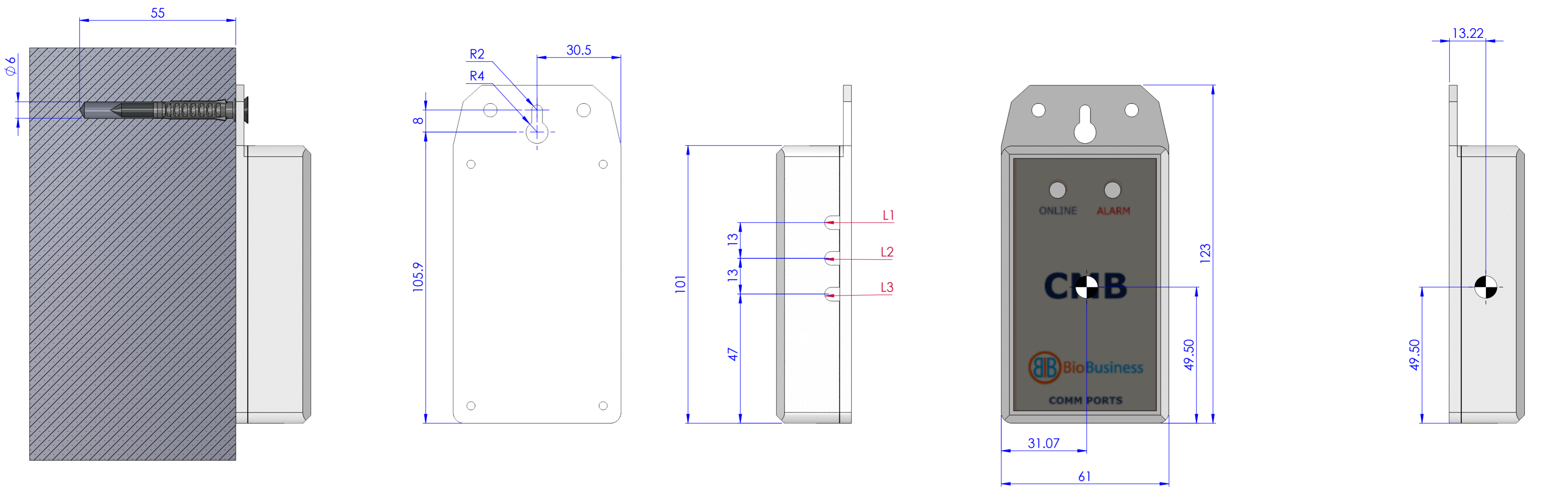

Anchor specification	
Plug	
Type	fischer SX
Drill Size	6
Material	Nylon
Recommended Tensile Load for Concrete C 25/30	0.4 kN
Screw	
DIN	7982 C
Type	Phillips flat countersunk head tapping screws
Screwdriver	PH2
Material	Steel Case - hardened 450 HV
Coating	Zinc Plated
Diameter	ST 4.8

Recommended Wall Material						
Concrete	Natural Stone	Limestone / Brick	Hollow limestone / Hollow Brick	Aircrete	Plaster walls	Gypsum fiberboard
•	•	•	•	•	•	○
• Suitable			○ Not Suitable			

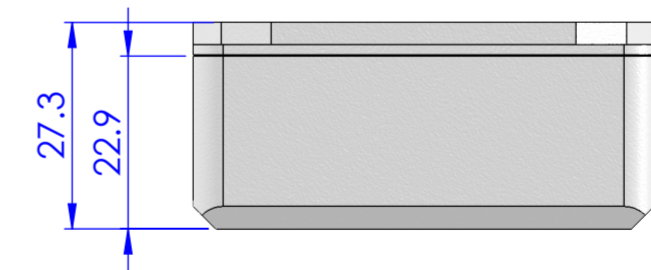

Weight without coils	89 g
Enclosure Material	ABS
Enclosure Thickness	2 mm



Commodit: Machined		SURFACE PROTECTION:		DEBURR AND BREAK SHARP EDGES		DO NOT SCALE DRAWING		PROJECT: Inspector		
UNLESS OTHERWISE SPECIFIED: DIMENSIONS ARE IN MILLIMETERS		Coating:		Color/RAL#:		FINISH:		DIMENSIONS INCLUDING COATING TOLERANCING : ISO 8015 - GENERAL TOLERANCE		
SURFACE FINISH:		Heat treatment:		Hardness:		FIRST ANGLE PROJECTION		TITLE: CMB Unit		
TOLERANCES: EN ISO 2768-mK		SEE PARTS		WEIGHT: 56.02 grams		SCALE: DON NOT SCALE		SHEET 1 OF 1		
				MODSB2A010		Reference #: R2160501-230-014		REVISION: 2		
DESIGN	NAME	DATE	MATERIAL:	SEE PARTS		BB#:		SIZE: A2		
DRAWN	Amr Saber	09-Mar-20	WEIGHT: 56.02 grams		SCALE: DON NOT SCALE		SHEET 1 OF 1		REVISION: 2	
APPVD		09-Mar-20	WEIGHT: 56.02 grams		SCALE: DON NOT SCALE		SHEET 1 OF 1		REVISION: 2	